

# Wall EV Charger User Manual AK-EC-21

Power: 11kW



Temperature  
Protection



Auto  
Repair



Efficient  
Charging



Protection  
Level IP54



RCD



High End  
MCU



Under Voltage  
Protection



Over Voltage  
Protection



Short Circuit  
Protection



Earth Leakage  
Protection



Lightning  
Protection





Over Load  
Protection



[www.akyga.com](http://www.akyga.com)

# Symbol Meaning

Symbol	Meaning
	<p>“Non-recyclable” mark: located on the product, instruction manual or package, indicating that electrical and electronic equipment and its accessories should be treated separately from ordinary household waste. When scrapped, it should be treated as industrial waste, otherwise it may cause accidents</p>
	<p>Warning sign: indicates danger. Pay attention to the personal injury that may be caused by operation procedure or incorrect operation. Actions after the “warning” mark can only be performed when the conditions indicated by the condition are fully understood and satisfied.</p>

The company is committed to the continuous improvement and update of the product, product hardware and software will continue to upgrade, the information provided is subject to change without prior notice.

Version:V2.0

Revision date:2023-08

# Product Overview

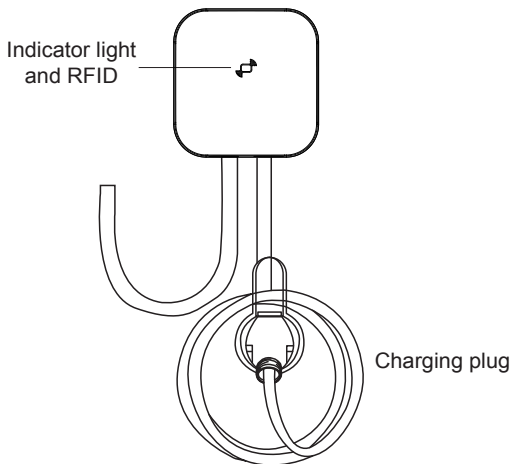

Appearance of Wall AC Charger

## Product Overview

- This product is a AC charging station, mainly used for AC charging of electric vehicles. The product is composed of charging station body, wall-hanging backboard, floor-to-ground column (optional), etc., with charging protection, charging by swiping card. This product adopts industrial design principle, easy to install and easy to use.
- Exterior: Exquisite and light, a variety of color options, suitable for different application scenarios.
- Protection: level of protection IP54(waterproof and dust-proof), can withstand wind, rain and sun exposure.
- Operation: The head of the charger is designed to open the cover with one button. The operation is simple and convenient, namely plug and play.
- Safety: multiple protection,safety upgrade, high quality materials, fireproof, waterproof and dust-proof.
- Commonality: Small body, big energy, compatible with 99% of the new energy vehicles.
- Quality: Pure copper wire without oxidation, comply with inspection standard, flame retardant impact resistance.
- The performance of the charger meets the requirements «IEC 62196-2-2011 Plugs, socket-outlets,vehicle connectors and vehicle inlets-Conductive charging of electric vehicles Part 2» relevant regulation.
- According to «IEC 61851-1-2012 Electric Vehicle Conductive Charging System Part 1» relevant regulation, and with reference to the "Electric Vehicle Charging Facilities Typical Design" part of the function of the design.The products fully meet the national and industrial standards for electric vehicles.

## Dimensions

Size: 180x180x85

Measurement Unit: mm

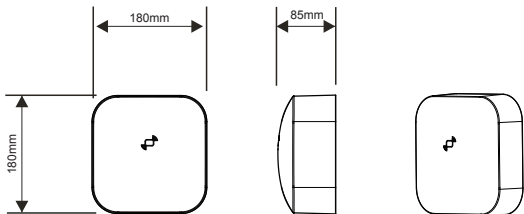

## Product Parameter

Charging Device	Rated Power	11kW
	User Interface	Indicator light
	Cable routing	Bottom inlet wiring, Bottom outlet wiring
	Charging model	Card swipe / APP
	Dimension	290x180x95mm
	Input voltage	3 phase; 380-440V
	Input frequency	50/60Hz
	Output voltage	380-440V
	Output current	16A
	Charging Wire length	5m
Protection Design	Over-current protection value	$\geq 110\%$
	Over-voltage protection value	465Vac for 3 phase
	Under-voltage protection value	330Vac for 3 phase
	Over-temperature protection value	85°C
	Electric leakage protection value	30mA AC+6mA DC
	PEN protector	Equipped inside
Environmental indicators	Work temperature	-35°C~50°C
	Work humidity	-5%~95% non-condensation
	Work altitude	<2000m
	Protection Level	IP54
	Cooling Model	Natural cooling
	MTBF	50,000 hours

# Installation

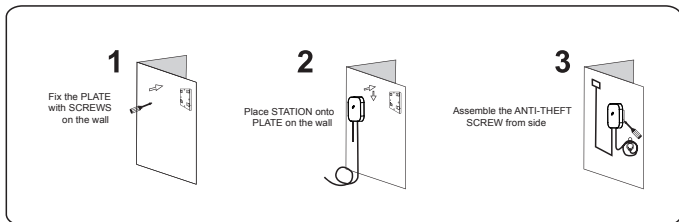

# Steps for Usage

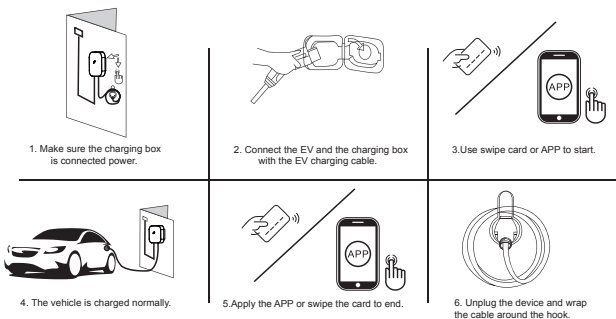

## NOTE:

1. After the vehicle is fully charged, the device will automatically stop charging.
2. Please read the instructions carefully before use.
3. For the App control(book time and switch current), operate after plug into vehicle (before charging), the current switch function will be valid even during charging.

## Steps for Power Wiring (3 phase; 11kW)

### PLAN A

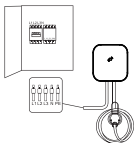

If a power distribution box is used, the L1, L2, L3, N, and PE ends of the input cable of the plug correspond to the L1, L2, L3, N, and PE ends of the circuit breaker respectively.

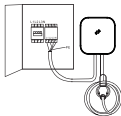

### PLAN B

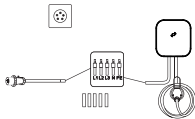

If the connection connector (the figure is just a diagram, customers can choose the appropriate plug according to their needs), then the heat shrinkable waterproof connector is needed to connect the two ends, pay attention to L1, L2, L3, N, PE corresponding connection, and use the crimping tool to squeeze the connection to ensure good contact.

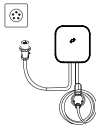

## Warning And Cautions

- For use only in the environment with RCD residual current protector;
- Do not use the device when the charging cable is damaged;
- For electric vehicle charging only;
- The product must be well grounded when used;
- It is strictly prohibited to step on the charging cable, pull the cable, bend or knot the cable.
- Do not put your finger into the charging plug.
- Do not connect thr circuit by yourself without the guidance of a professional.
- Do not use when the inside of the charging plug is wet.
- Do not install by yourself before reading the installation instruction.
- Do not use for other purposes except for electric car charging.
- SPECIAL ATTENTION:Do not try to disassemble the device by yourself under any circumstances, this may cause damage to the internal precise parts, and you will not be able to mjoy after-sales service.

## Fault Indicator Prompt

Working state	Red	Green	Blue
Power On(Unplugged)	/	Stays On	/
Insert the Plug(Uncharged)	/	Flashing	/
Charging Mode	/	/	Flashing
Charging Completed	/	/	Stays On
Leakage Protection	Flash for 1	/	/
Over Current Protection	Flash for 2	/	/
Ground Fault(Ungrounded)	Flash for 3	/	/
Under/Over Voltage Alarm	Flash for 4	/	/
Relay Failure	Flash for 5	/	/
CP/CC Error	Flash for 6	/	/





Remark: Error frequency is flashing certain times with 200ms interval, continuous loop with 1s interval.

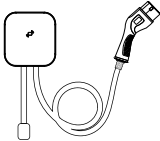

## Common Trouble Handling

Fault	Reasons	Suggestions
Excessive Leakage Current	Excessive Leakage Current	1. Disconnect the leakage/over current protection switch of the distribution box immediately.
		2. Check whether the AC charger output line is damaged or has low impedance to the ground or short circuit.
		3. Check the inlet socket of the vehicle is in good condition or not.
		4. After troubleshooting the above problems, power on again. If the problem still exists, please contact us.
AC Overcurrent	High Input Current	1. Disconnect the leakage/over current protection switch of the distribution box immediately.
		2. Check whether there is low impedance or short circuit between the two output lines of AC charger.
		3. After troubleshooting the above problems, power on again. If the problem still exists, please contact us.
Ground Fault	Failure Grounding do Input/ Output Line	1. Disconnect the leakage/over current protection switch of the distribution box immediately.
		2. Check whether the input/output line of the AV charger is grounded properly or not.
		3. After troubleshooting the above problems, power on again. If the problem still exists, please contact us.
AC Under-Voltage	Low Input Voltage	1. If the voltage is lower than 330Vac for 3 phase for a short period of time, the charger will stand by and check the power network to restore itself to the normal voltage range, then the charger will automatically rework.
		2. If the voltage in this area/community is under-voltage for a long time(330Vac for 3 phase), then wait to use the charger only after the voltage recovers back to normal range.
AC Over-Voltage	High Input Voltage	1. If the voltage exceeds 465Vac for 3 phase for a short period of time, the charger will stand by and check the power network to restore itself to the normal voltage range, then the charger will automatically rework.
		2. If the voltage in this area/community is over-voltage for a long time(465Vac for 3 phase), then wait to use the charger only after the voltage recovers back to normal range.
Relay Failure	Relay Failure or Adhesion	1. Restart the charger, let the charger run itself check and repair.
		2. If fault persists, please contact us.
CP/CC Error	Charger CP/CC Connection Error	1. Check whether the connection of charging plug with the inlet socket of vehicle is tight and reliable or not.
		2. If the fault persists, please contact us.

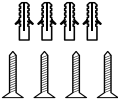
## WHAT'S IN THE BOX

		
Charging station x1 Charging plug (opt)	RFID card x 2	Hanging board x 1
 M3.5*35mm	 M3*10mm	
Rubber plugs + Screws for hanging board x 4	Side anti-theft screws for hanging board x 2	User Manual x 1 APP User Manual (opt)

  
www.akyga.com